

Digital Gauge DL-BR

Gauges suitable for installation on machines

- Magnetic principle
- Excellent resistance to workshop conditions (IP64). Resistant to oil, dust, vibrations and shocks.
- Built-in zero point
- A/B phase output and zero point signal output by open collector.
- Measuring range: 10 mm / 0.39", 30 mm / 1.18" and 60 mm / 2.36"
- Easy mounting and maintenance thanks to stem mount design.

Specifications

Model	DL10BR	DL30BR	DL60BR
Measuring range	10 mm / 0.39" (after passing zero point)	30 mm / 1.18" (after passing zero point)	60 mm / 2.36" (after passing zero point)
Resolution *1	5 μm		
Accuracy (at 20 °C / 68 °F)	± 2.5 μm		
Measuring force	5.3 N or less		7.0 N or less
Max.response speed *2	120 m/ min		
Zero point repeatability	1 count or less		
Zero point detection speed	10 m/ min		
Zero point	1 ± 0.5 mm from feeler end fully retracted		
Output signal	A/B phase (7406 equivalent, 24 VDC, 20 mA or less) and zero point signal by NPN open collector		
Protective design grade	Equivalent to IP64		
Mounting stem diameter	ø 20 ⁰ _{-0.013} mm		
Operating temperature	-0 °C to 50 °C / 32 °F to 122 °F		
Storage temperature	-20 °C to 60 °C / -94 °F to 140 °F		
Power supply	5 VDC ^{+5%} ₀		
Power consumption	0.5 W		
Cable length	5 m / 16.4'		
Feeler	Feeler tipped with 3 mm dia. carbide ball with M2.5 x 0.45 screw on fitting end (DZ123)		
Mass (excl. cable unit) *3	0.45 kg / 0.99 lbs		0.55 kg / 1.21 lbs

*2 Max. response speed of the electrical circuit.
*3 Mass of the cable not included.

Dimensions

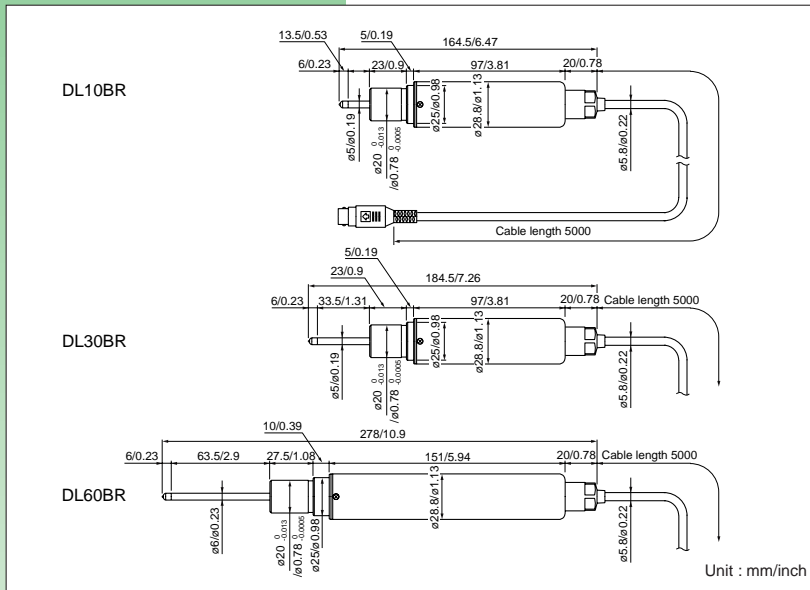

*1 Resolution
→ 5 μm (90° difference of A/B phase output Note 1)

*2 Duty Cycle of A/B phase signal
→ T/4 ± T/8 (Note 1)

Note 1

